

## Thickness Measurement of Slab or Plate

### Problem:

To accurately measure the thickness of slab or plate

### Solution:

Use triangulation laser meters to measure the top and bottom surfaces of the material.

### Equipment:

- Two LM-500-LR7 triangulation laser meters mounted in a 'C' frame
- 

### Features:

- Non contact
- Accuracy to 0.21mm
- Safety
- Easy installation and maintenance

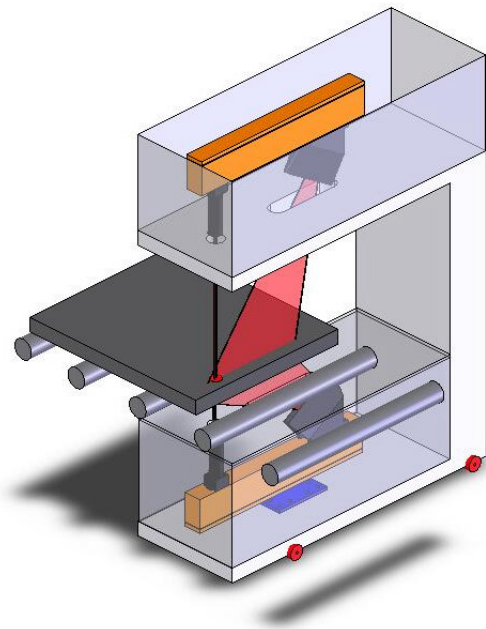

### Locations:

Slab Casters, Reheat Furnaces, Entry Roller Tables, Plate Mills