

Strip Centering

Problem:

Measure positions of edges of the strip for centering, camber measurement, width measurement

Solution :

Use an IS-3000 width scanner

Equipment:

- IS-3000-CW Infrared Scanner and two RB-3000 Radiant Bars for cold product
or
- IS-3000-HW for hot product

Features:

- Non contact
- Accuracy
- Safety
- Easy installation and maintenance

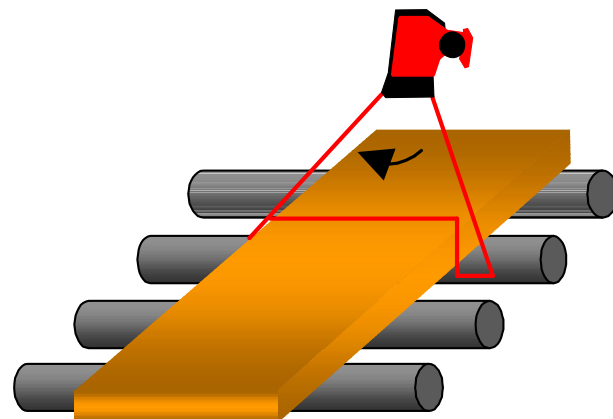
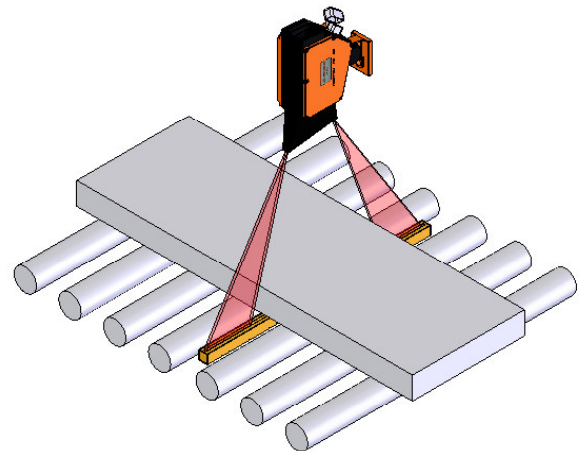

Locations:

Hot or cold Mills