

Strip Centering

Problem:

Measure positions of edges of the strip for centering, camber measurement, width measurement

Solution :

Use an IS-3000 width scanner

Equipment:

- IS-3000-CW Infrared Scanner and two RB-3000 Radiant Bars for cold product
or
- IS-3000-HW for hot product

Features:

- Non contact
- Scanning range: $\pm 22^\circ$
- Accuracy: 1/10" on each edge
- Resolution: 1/100"
- Two analog outputs (4-20mA)
- Serial output: RS232 & RS485
- Easy installation and maintenance

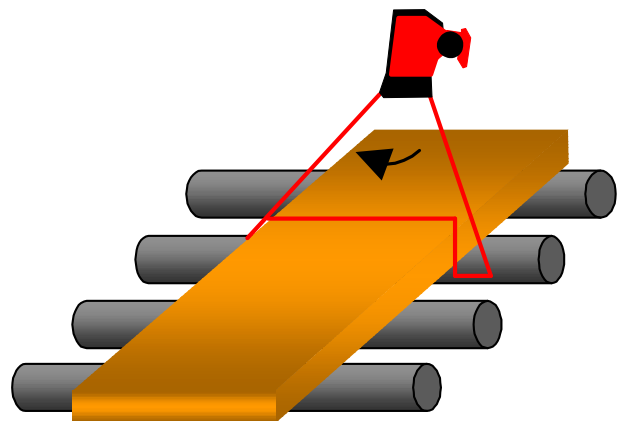
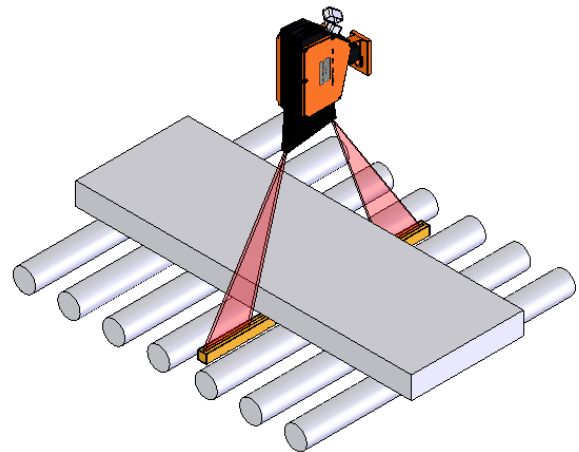

Locations:

Hot or cold Mills