

Snapshot Method of Length & Position Measurement

Problem:

Measure the length and position as well as speed for controlled slow down and stop

Solution:

Laser based position and length measurement of billet, bloom, and slab

Equipment:

- OB 3000-F, Optical barrier and LM 3000, Laser Meter (Cold)
- HMD 3000, Hot Metal Detector and LM-3000 Laser Meter (Hot)

Features:

- Non contact Sensor
- Accuracy: 1/4"
- Easy installation and maintenance
- Rugged and reliable

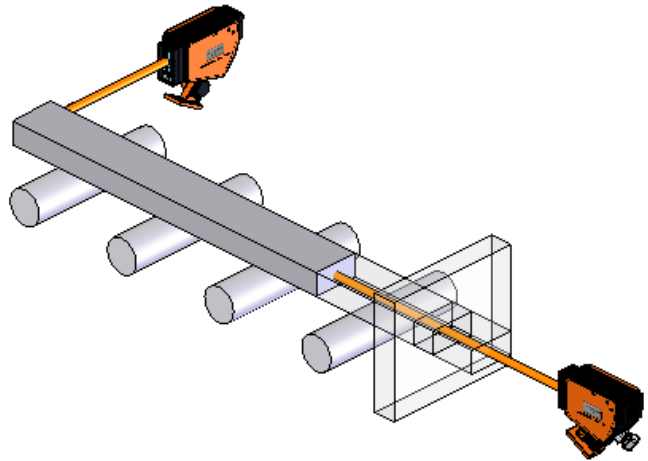

Locations:

Billet, bloom, and slab continuous casters
and roller tables at entry of reheat
furnaces